

Clean Agent FS 49 C2[®] System

Halon 1301 Replacement Systems

FS 49 C2[®] was developed to provide a Halon 1301 replacement system, offering the same optimum characteristics yet with minimum impact on the environment.

FS 49 C2[®] systems are installed to protect computer rooms, engines, transformers, switchboards and other areas at risk. These systems are designed for a quick discharge that fills the room quickly and efficiently without endangering personnel.

The FS 49 C2[®] system was developed with almost identical characteristics to Halon 1301 systems which can easily be converted to FS 49 C2[®] systems, using existing hardware and with minor technical adjustments as well as a slight increase in gas storage volume. (Assessment of this factor should be left to competent engineers).

Hence, FS 49 C2[®] is considered the best and most ideal choice for a new installation or upgrade/replacement of an existing Halon 1301 system to an environmentally friendly system.



FS 49 C2[®] Advantages

- An ozone friendly clean extinguishing agent with 'zero' ODP factor
- Compatible with Halon technology
- May be used in existing Halon systems
- Quick-acting — Fast extinction
- Favourable weight/volume ratio
- No hazards to humans at extinguishing concentrations
- Thoroughly tested — favourable user response
- Suitable for explosion suppression

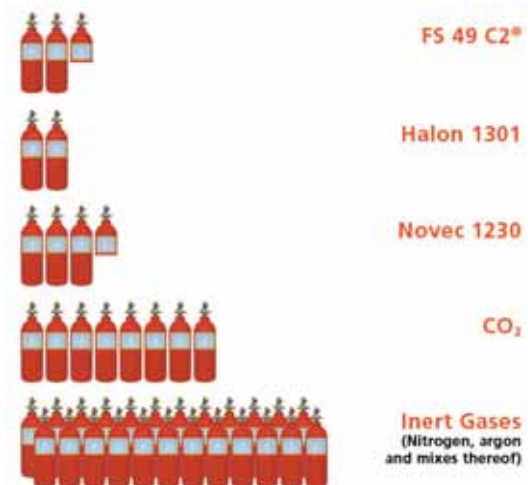

FS 49 C2[®] is stored in condensed form at 25 or 42 bar, a slight increase in nozzle size and storage capacity is required in comparison with Halon 1301 systems. Release arrangement and pipe network in existing systems can be used.

“The Sensible Solution to a Global Dilemma”

Clean Agent FS 49 C2[®] System

Halon 1301 Replacement Systems

Installing a New System

FS 49 C2[®] is the ideal extinguishing agent of choice for a new system as it is safe, clean and when used, leaves no residue to be cleaned up, mopped up or scraped off.

Any residue is usually harmless to any equipment, hence production downtime, if any, is greatly reduced. Furthermore, FS 49 C2[®] is quick acting, which keeps fire damage to a minimum.

Like Halon 1301, FS 49 C2[®] has an ideal weight/volume ratio and is condensed in the cylinder and stored in liquid form, making a great reduction in use of floor space and weight.

"Drop In" Gas

Replacing Halon 1301 with FS 49 C2[®] means great savings for you when upgrading your existing system.

Minor technical adjustment as well as slightly increases in gas storage capacity is all that is required.

However, when converting to FS 49 C2[®], a complete analysis should be performed and assessments of these factors should be left to trained engineers.

Upgrade/Replacement

Most existing clean agent systems like Halon 1301 are installed to protect computer systems, control rooms or vital installations. This is where the FS 49 C2[®] is one of the most favorable alternatives for conversion or upgrading, in comparison to other extinguishing medium systems.

FS 49 C2[®] is designed with a quick discharge that fills the room quickly and fully without reaching levels that endanger personnel. The concentrations needed to extinguish the fire are not dangerous to humans.

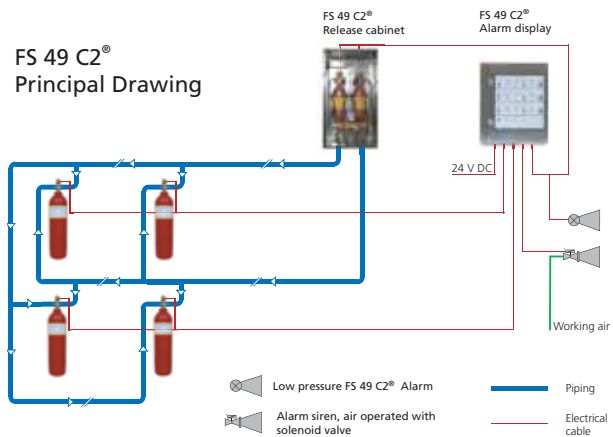

“The Sensible Solution to a Global Dilemma”

Clean Agent FS 49 C2[®] System

Halon 1301 Replacement Systems



Safe Lancia

Built by GVA for Con-safe



M/S Viscaya

Built by Öresundsvarvet for HDS & Co A/S.



Statsraad Lemkuhl

Engine room protected by FS 49 C2[®].



The Hamina Class

Missile boats
Built by Aker Finnyards for the Finnish Navy



Combat Boat 90 (CB90)

Built by Dockstavarvet for the Swedish, Norwegian, Mexican and Malaysian Navies.



HMS Stockholm

Built by Kockums for the Swedish Navy.

The FFS Principle

FFS, or Fail - Fail - Safe, is based on the principle of functional redundancy. A vessel fitted with a FFS system can deploy its FS 49 C2[®] system even if one or more of its release mechanisms have failed.

This system is unique in having this high level of safety and functionality.

The HMS Visby Solution

Imagine a war ship incapable of carrying out its mission because of a small, but critical fire!

This scenario is unlikely for HMS Visby. The HMS Visby solution is a fire extinguishing system based on Clean Agent FS 49 C2[®] and FFS.

The system has been developed together with the Swedish Navy for a number of years using the best of knowledge and experience possible to find the best solution for war ships.



“The Sensible Solution to a Global Dilemma”

Clean Agent FS 49 C2[®] System

Halon 1301 Replacement Systems

Physical Properties of Clean Agent FS 49 C2[®]

Commonly used name	Clean Agent FS 49 C2
Trade name	FS 49 C2
Technical denomination	HFC 3-4-9 C2/(R866)
Application	Total flooding systems

Environmental Properties

Ozone Depleting Potential (ODP)	0
Global Warming Potential (HGWP)	0,35

Physical Properties

Molecular Weight	99,49
Boiling Point oC	Lowest -78,5
Liquid Density @ 20 oC kg/dm ³	1,19
Vapour Pressure @ 20 oC bar	14,9

Extinguishing Concentrations

n-heptane, cup burner % by vol.	8,5
REMP value, agent/fuel ratio	10 – 13
Inerting Concentration % by vol. (Flammability limit, propane)	12 - 14

Acute Toxicity

ALC LC50 4 hrs % by vol.	>50
NOAL % by vol.	>13
LOAL % by vol.	>15

Approved/Accepted and/or Tested by

- Swedish Maritime Administration
- Norwegian Maritime Directorate
- Finnish Maritime Directorate
- Bureau Veritas
- American Bureau of Shipping – ABS
- Maritime & Port Authority of Singapore
- Marine Administration, Isle of Man
- Swedish Armed Forces
- Norwegian Armed Forces
- Institute of Science and Technology
Department of Fire Safety Engineering,
University of Lund, Sweden
- SP, Swedish National
Testing & Research Institute
- ISO norms by SP
- CEA norms by SP
- IMO guidelines MSC/Circ. 776, 848
- M.E.D - Marine Equipment Directive 96/98/EC
- Germanischer Lloyd
- Danish Maritime Authority
- Maritime and Coastguard Agency (MCA)

